

 **TOYOTA**
PRIUS

Gasoline-Electric

Hybrid Synergy Drive

HYBRID VEHICLE
DISMANTLING
MANUAL



ZVW30 Series

Foreword

This guide was developed to educate and assist dismantlers in the safe handling of Toyota Prius gasoline-electric hybrid vehicles. Prius dismantling procedures are similar to other non-hybrid Toyota vehicles with the exception of the high voltage electrical system. It is important to recognize and understand the high voltage electrical system features and specifications of the Toyota Prius hybrid, as they may not be familiar to dismantlers.

High voltage electricity powers the A/C compressor, electric motor, generator, and inverter/converter. All other conventional automotive electrical devices such as the headlights, radio, and gauges are powered from a separate 12 Volt auxiliary battery. Numerous safeguards have been designed into the Prius to help ensure the high voltage, approximately 201.6 Volt, Nickel Metal Hydride (NiMH) Hybrid Vehicle (HV) battery pack is kept safe and secure in an accident.

The NiMH HV battery pack contains sealed batteries that are similar to rechargeable batteries used in some battery operated power tools and other consumer products. The electrolyte is absorbed in the cell plates and will not normally leak out even if the battery is cracked. In the unlikely event the electrolyte does leak, it can be easily neutralized with a dilute boric acid solution or vinegar.

High voltage cables, identifiable by orange insulation and connectors, are isolated from the metal chassis of the vehicle.

Additional topics contained in the guide include:

- Toyota Prius identification.
- Major hybrid component locations and descriptions.

By following the information in this guide, dismantlers will be able to handle Prius-electric vehicles as safely as the dismantling of a conventional non-hybrid automobile.

© 2009 Toyota Motor Corporation

All rights reserved. This book may not be reproduced or copied, in whole or in part, without the written permission of Toyota Motor Corporation.

Table of Contents

<u>About the Prius</u>	<u>1</u>
<u>Prius Identification</u>	<u>2</u>
Exterior	3
<u>Prius Identification (Continued)</u>	<u>4</u>
Interior	4
Engine Compartment	5
<u>Hybrid Component Locations & Descriptions</u>	<u>6</u>
Specifications	7
<u>Hybrid Synergy Drive Operation</u>	<u>8</u>
Vehicle Operation	8
<u>Hybrid Vehicle (HV) Battery Pack and Auxiliary Battery</u>	<u>9</u>
HV Battery Pack	9
Components Powered by the HV Battery Pack	9
HV Battery Pack Recycling	10
Auxiliary Battery	10
<u>High Voltage Safety</u>	<u>11</u>
High Voltage Safety System	11
Service Plug Grip	12
<u>Precaution to be observed when dismantling the vehicle</u>	<u>13</u>
Necessary Items	13
<u>Spills</u>	<u>14</u>
<u>Dismantling the vehicle</u>	<u>15</u>
<u>Removal of HV battery</u>	<u>18</u>
HV Battery Caution Label	28

About the Prius

The Prius continues into its 3rd generation as a gasoline-electric hybrid vehicle. Hybrid Synergy Drive means that the vehicle contains a gasoline engine and electric motors for power. The two hybrid power sources are stored on board the vehicle:

1. Gasoline stored in the fuel tank for the gasoline engine.
2. Electricity stored in a high voltage Hybrid Vehicle (HV) battery pack for the electric motor.

The result of combining these two power sources is improved fuel economy and reduced emissions. The gasoline engine also powers an electric generator to recharge the battery pack; unlike a pure all electric vehicle, the Prius never needs to be recharged from an external electric power source.

Depending on the driving conditions one or both sources are used to power the vehicle. The following illustration demonstrates how the Prius operates in various driving modes.

- ❶ During light acceleration at low speeds, the vehicle is powered by the electric motor. The gasoline engine is shut off.
- ❷ During normal driving, the vehicle is powered mainly by the gasoline engine. The gasoline engine also powers the generator to recharge the battery pack.
- ❸ During full acceleration, such as climbing a hill, both the gasoline engine and the electric motor power the vehicle.
- ❹ During deceleration, such as when braking, the vehicle regenerates the kinetic energy from the wheels to produce electricity that recharges the battery pack.
- ❺ While the vehicle is stopped, the gasoline engine and electric motor are off, however the vehicle remains on and operational.

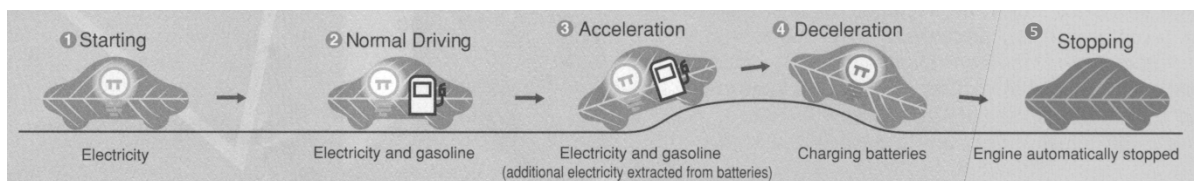

Prius Identification

In appearance, the 2010 model year Prius is a 5-door hatchback. Exterior, interior, and engine compartment illustrations are provided to assist in identification.

The alphanumeric 17 character Vehicle Identification Number (VIN) is provided in the front windshield cowl and on the driver door pillar.

Example VIN: JTDKN3DUA82020211

A Prius is identified by the first 8 alphanumeric characters JTDKN3DU.

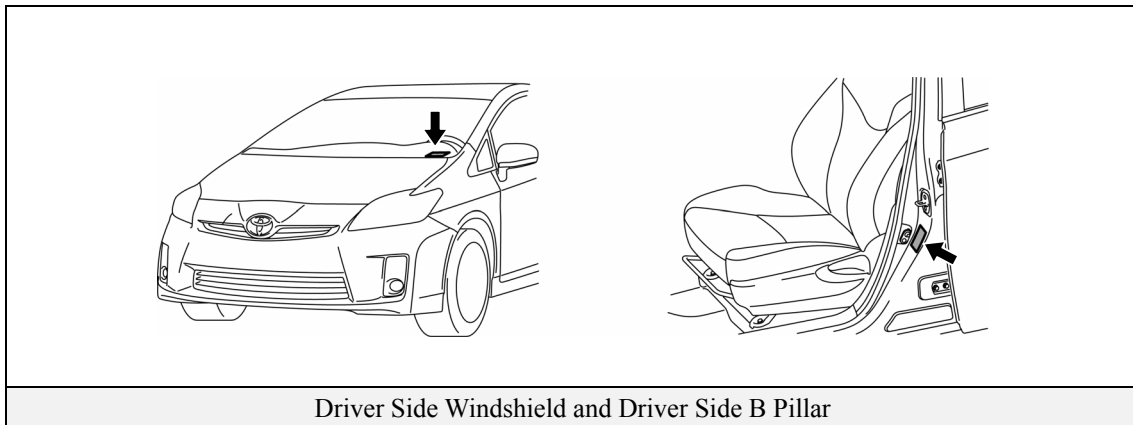

Prius Identification (Continued)

Exterior

- ❶ **PRIUS** and  logos on the back door.
- ❷ Gasoline fuel filler door located on driver side rear quarter panel.
- ❸ **HYBRID** logo on each front fender.



Exterior Driver Side View



Exterior Front View



Exterior Rear View



Exterior Rear and Driver Side View

Prius Identification (Continued)

Interior

- ④ Instrument cluster (speedometer, **READY** light, shift position indicators, warning lights) located in center of the dash and near the base of the windshield.

Hint:

If the vehicle is shut off, the instrument cluster gauges will be “blacked out”, not illuminated.

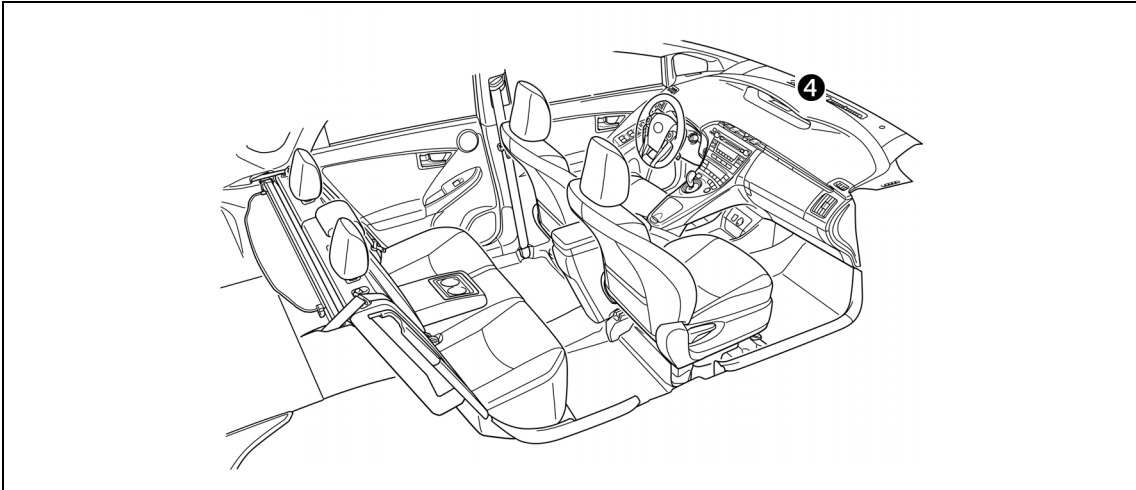

Interior View of Front Door Sill/Scuff Plate

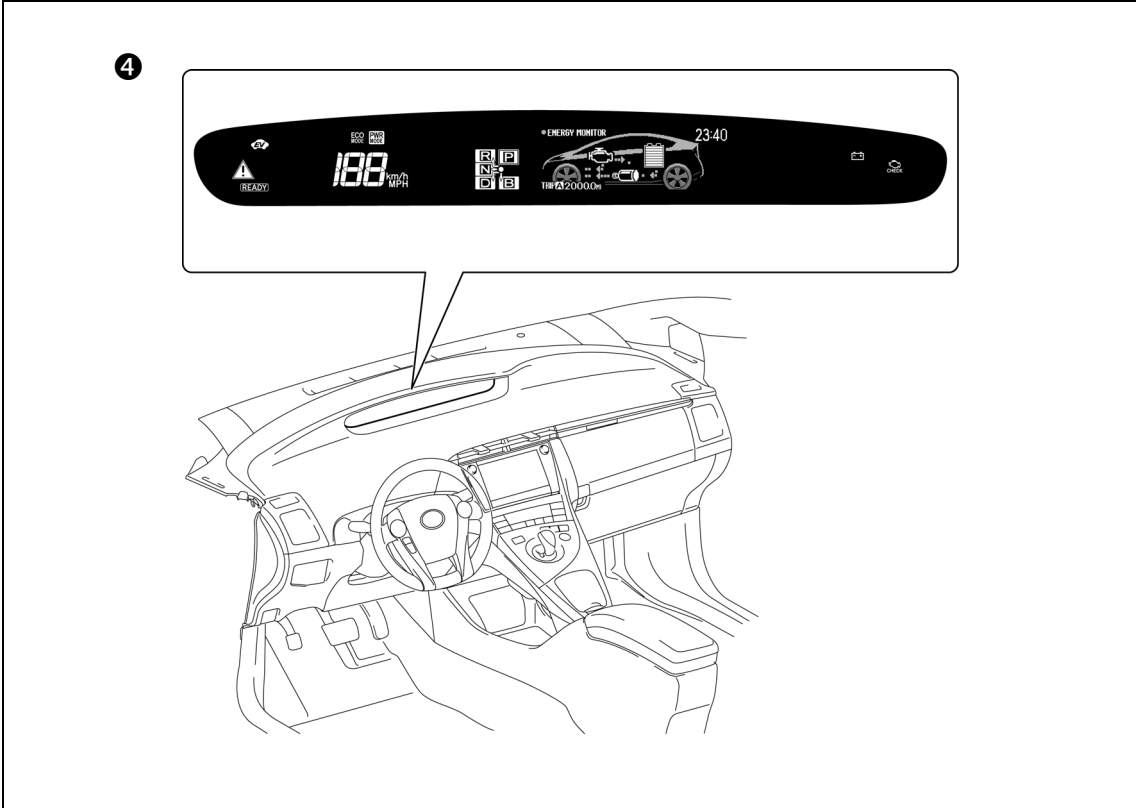

Instrument Cluster View

Prius Identification (Continued)

Engine Compartment

- ⑤ 1.8-liter aluminum alloy gasoline engine.
- ⑥ High voltage inverter/converter assembly with logo on the cover.
- ⑦ Orange colored high voltage power cables.

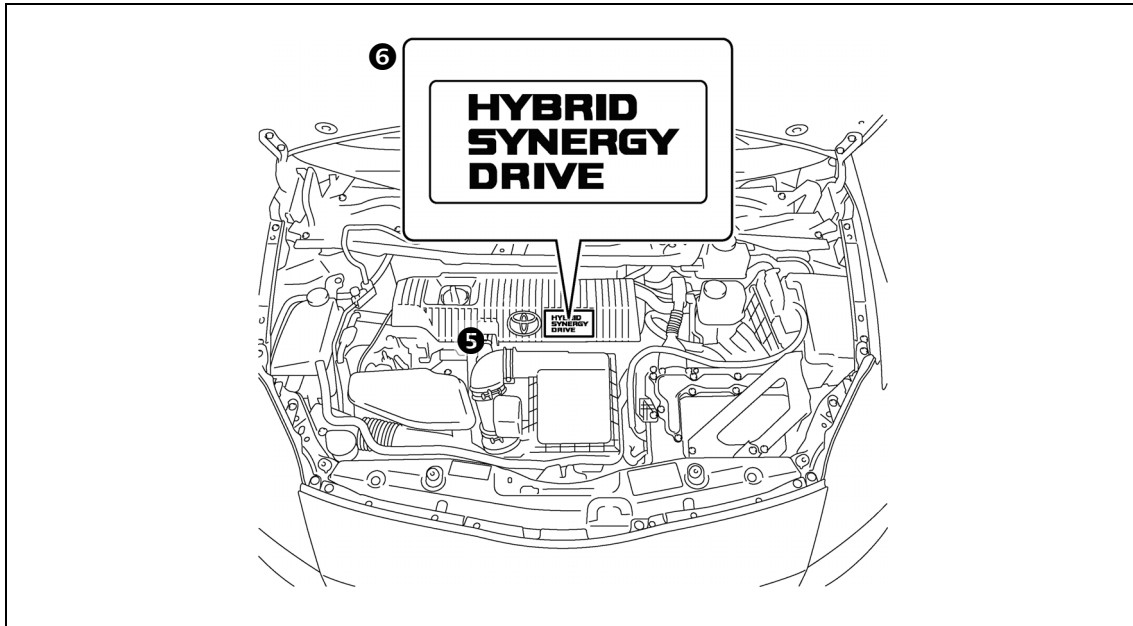

Engine Compartment View

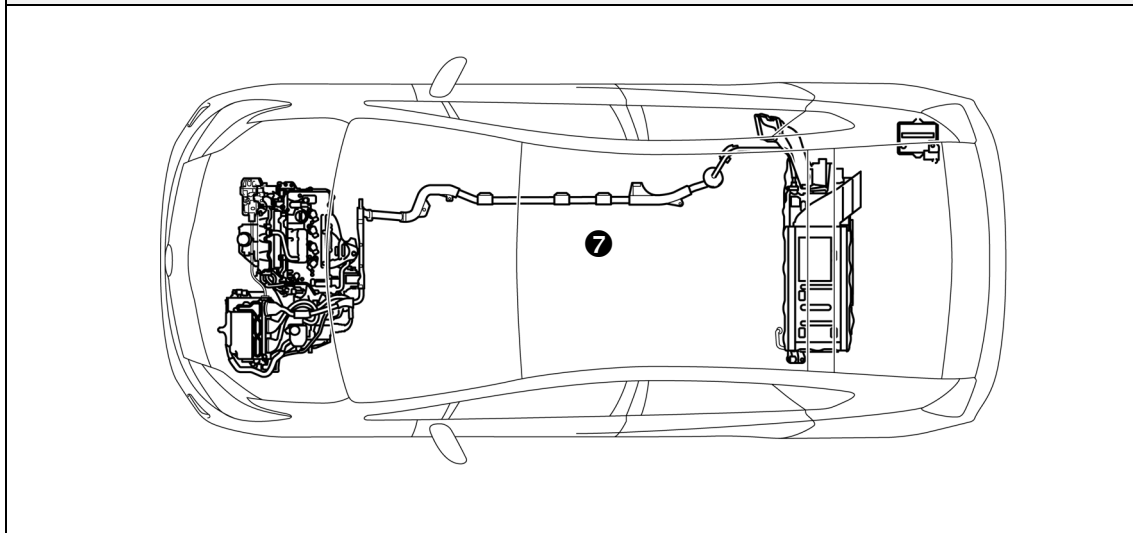

Power Cables

Hybrid Component Locations & Descriptions

Component	Location	Description
12 Volt ❶ Auxiliary Battery	Passenger Side of Cargo Area	A lead-acid battery that supplies power to the low voltage devices.
Hybrid ❷ Vehicle (HV) Battery Pack	Cargo Area, Mounted to Cross Member behind Rear Seat	201.6 Volt Nickel Metal Hydride (NiMH) battery pack consisting of 28 low voltage (7.2 Volt) modules connected in series.
Power ❸ Cables	Undercarriage and Engine Compartment	Orange colored power cables carry high voltage Direct Current (DC) between the HV battery pack, inverter/converter, and A/C compressor. These cables also carry 3-phase Alternating Current (AC) between the inverter/converter, electric motor, and generator.
Inverter/ Converter ❹	Engine Compartment	Boosts and inverts the high voltage electricity from the HV battery pack to 3-phase AC electricity that drives the electric motors. The inverter/converter also converts AC electricity from the electric generator and electric motors (regenerative braking) to DC that recharges the HV battery pack.
Gasoline ❺ Engine	Engine Compartment	Provides two functions: 1) Powers vehicle. 2) Powers generator to recharge the HV battery pack. The engine is started and stopped under control of the vehicle computer.
Electric ❻ Motor	Engine Compartment	3-phase high voltage AC permanent magnet electric motor contained in the front transaxle. It is used to power the front wheels.
Electric ❼ Generator	Engine Compartment	3-phase high voltage AC generator that is contained in the transaxle and recharges the HV battery pack.
A/C Compressor (with Inverter) ❸	Engine Compartment	3-phase high voltage AC electrically driven motor compressor.
Fuel Tank and Fuel Line ❾	Undercarriage and Center	The fuel tank provides gasoline via a fuel line to the engine. The fuel line is routed under the center of vehicle.

*Numbers in the component column apply to the illustrations on the following page.

Hybrid Component Locations & Descriptions (Continued)

Specifications

Gasoline Engine:	98 hp (73 kW), 1.8-liter Aluminum Alloy Engine
Electric Motors	80 hp (60 kW), Permanent Magnet Motor
Transmission:	Automatic Only (electrically controlled continuously variable transaxle)
HV Battery:	201.6 Volt Sealed NiMH-Battery
Curb Weight:	3,080 lbs/1,397 kg
Fuel Tank:	11.9 gals/45.0 liters
Fuel Economy	
Ratings:	51/48 (City/Hwy) miles/gal 4.7/4.8 (City/Hwy) liters/100 km
Frame Material:	Steel Unibody
Body Material:	Steel Panels except for Aluminum Hood and Back Door
Seating Capacity:	5 standard

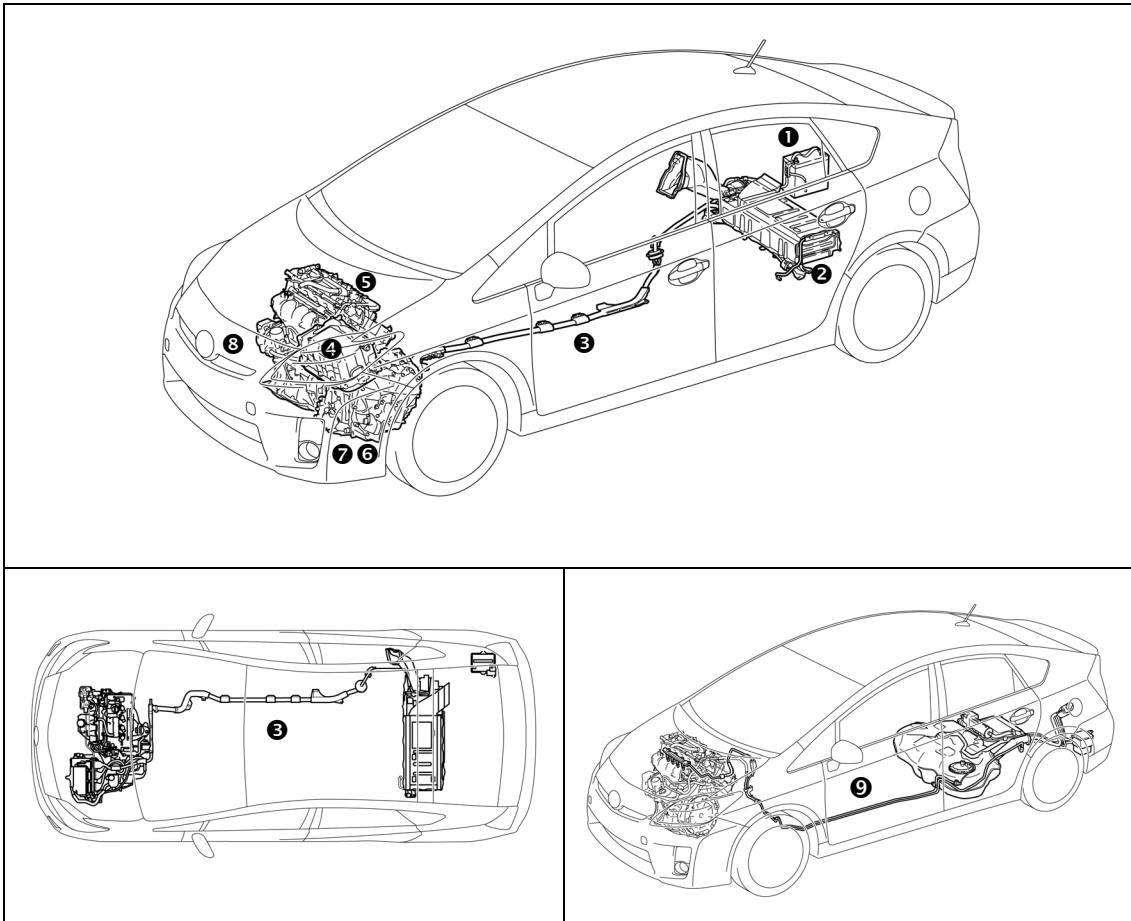

Hybrid Synergy Drive Operation

Once the **READY** indicator is illuminated in the instrument cluster, the vehicle may be driven. However, the gasoline engine does not idle like a typical automobile and will start and stop automatically. It is important to recognize and understand the **READY** indicator provided in the instrument cluster. When illuminated, it informs the driver that the vehicle is on and operational even though the gasoline engine may be off and the engine compartment is silent.

Vehicle Operation

- With the Prius, the gasoline engine may stop and start at any time while the **READY** indicator is on.
- Never assume that the vehicle is shut off just because the engine is off. Always look for the **READY** indicator status. The vehicle is shut off when the **READY** indicator is off.

The vehicle may be powered by:

1. The electric motor only.
2. The gasoline engine only.
3. A combination of both the electric motor and the gasoline engine.

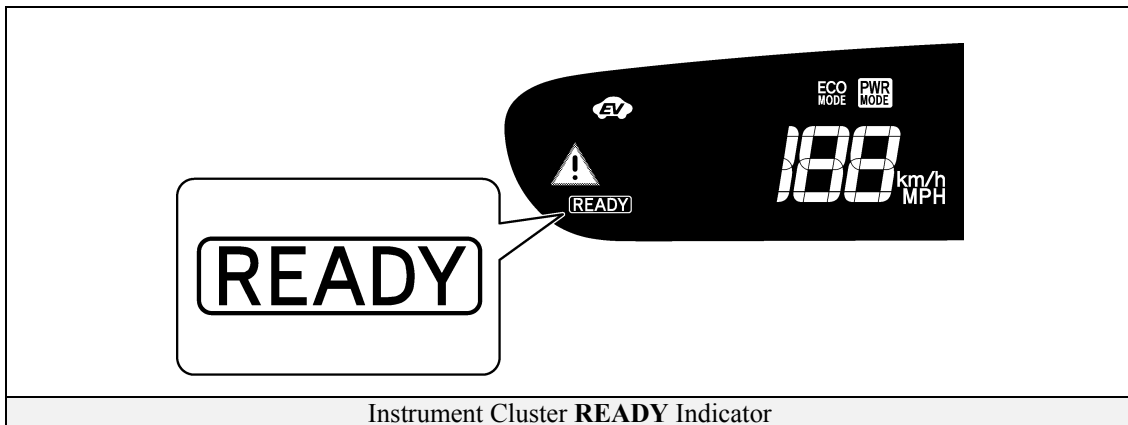

Hybrid Vehicle (HV) Battery Pack and Auxiliary Battery

The Prius features a high voltage Hybrid Vehicle (HV) battery pack that contains sealed Nickel Metal Hydride (NiMH) battery modules.

HV Battery Pack

- The HV battery pack is enclosed in a metal case and is rigidly mounted to the cargo area floor pan cross member behind the rear seat. The metal case is isolated from high voltage and concealed by carpet in the cabin area.
- The HV battery pack consists of 28 low voltage (7.2 Volt) NiMH battery modules connected in series to produce approximately 201.6 Volts. Each NiMH battery module is non-spillable and in a sealed case.
- The electrolyte used in the NiMH battery module is an alkaline mixture of potassium and sodium hydroxide. The electrolyte is absorbed into the battery cell plates and will not normally leak, even in a collision.
- In the unlikely event that the battery pack is overcharged, the modules vent gases directly outside the vehicle through a vent hose.

HV Battery Pack	
Battery pack voltage	201.6 V
Number of NiMH battery modules in the pack	28
NiMH battery module voltage	7.2 V
NiMH battery module dimensions	11.2 x 0.8 x 4.6 in (285 x 19.6 x 117.8 mm)
NiMH module weight	2.3 lbs (1.04 kg)
NiMH battery pack dimensions	11.7 x 23.2 x 0.42 in (297 x 590 x 10.7 mm)
NiMH battery pack weight	90 lbs (41 kg)

Components Powered by the HV Battery Pack

- Electric Motor
- Inverter/Converter Motor
- Power Cables
- A/C Compressor
- Electric Generator

Hybrid Vehicle (HV) Battery Pack and Auxiliary Battery (Continued)

HV Battery Pack Recycling

- The HV battery pack is recyclable. Contact either your Toyota Distributor as mentioned on HV battery Caution Label (see page 28) or the nearest Toyota dealer.

Auxiliary Battery

- The Prius also contains a lead-acid 12 Volt battery. This 12 Volt auxiliary battery powers the vehicle electrical system similar to a conventional vehicle. As with other conventional vehicles, the auxiliary battery is grounded to the metal chassis of the vehicle.
- The auxiliary battery is located in the cargo area. It is concealed by a fabric cover on the passenger side in the rear quarter panel well.

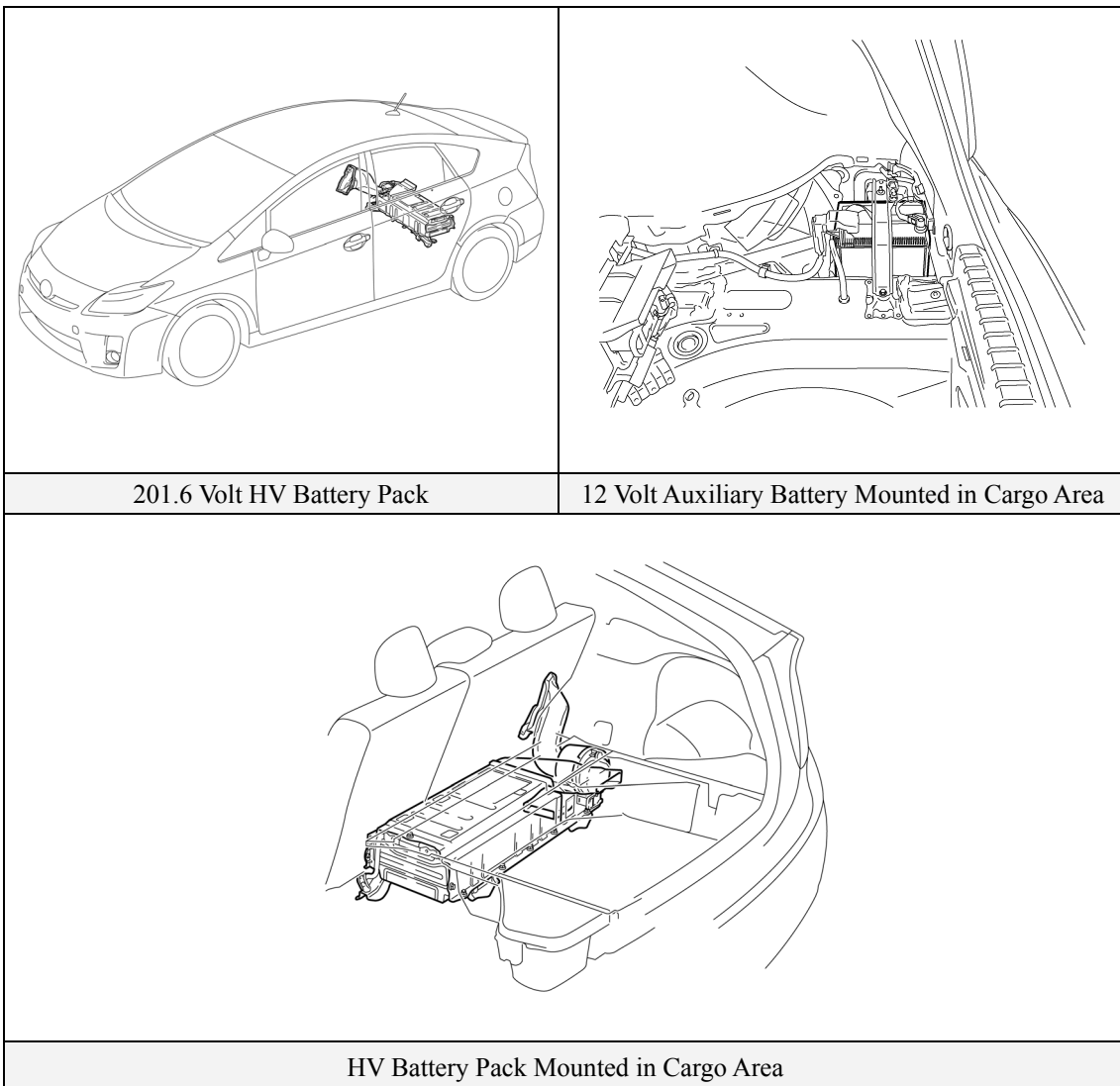

High Voltage Safety

The HV battery pack powers the high voltage electrical system with DC electricity. Positive and negative orange colored high voltage power cables are routed from the battery pack, under the vehicle floor pan, to the inverter/converter. The inverter/converter contains a circuit that boosts the HV battery voltage from 201.6 to 650 Volts DC. The inverter/converter creates 3-phase AC to power the motors. Power cables are routed from the inverter/converter to each high voltage motor (front and rear electric motors, electric generator, and A/C compressor). The following systems are intended to help keep occupants in the vehicle and emergency responders safe from high voltage electricity:

High Voltage Safety System

- A high voltage fuse ❶* provides short circuit protection in the HV battery pack.
- Positive and negative high voltage power cables ❷* connected to the HV battery pack are controlled by 12 Volt normally open relays ❸*. When the vehicle is shut off, the relays stop electricity flow from leaving the HV battery pack.



WARNING:

- ***The high voltage system may remain powered for up to 10 minutes after the vehicle is shut off or disabled. To prevent serious injury or death from severe burns or electric shock, avoid touching, cutting, or opening any orange high voltage power cable or high voltage component.***

- Both positive and negative power cables ❷* are insulated from the metal chassis, so there is no possibility of electric shock when touching the metal chassis.
- A ground-fault monitor continuously monitors for high voltage leakage to the metal chassis while the vehicle is running. If a malfunction is detected, the hybrid vehicle computer ❹* will illuminate the master warning light  in the instrument cluster and indicate “CHECK HYBRID SYSTEM” on the multi-information display.
- The HV battery pack relays will automatically open to stop electricity flow in a collision sufficient to activate the SRS.

*Numbers apply to the illustration on the following page.

High Voltage Safety (Continued)

Service Plug Grip

- The high-voltage circuit is cut by removing the service plug grip (see page 15).

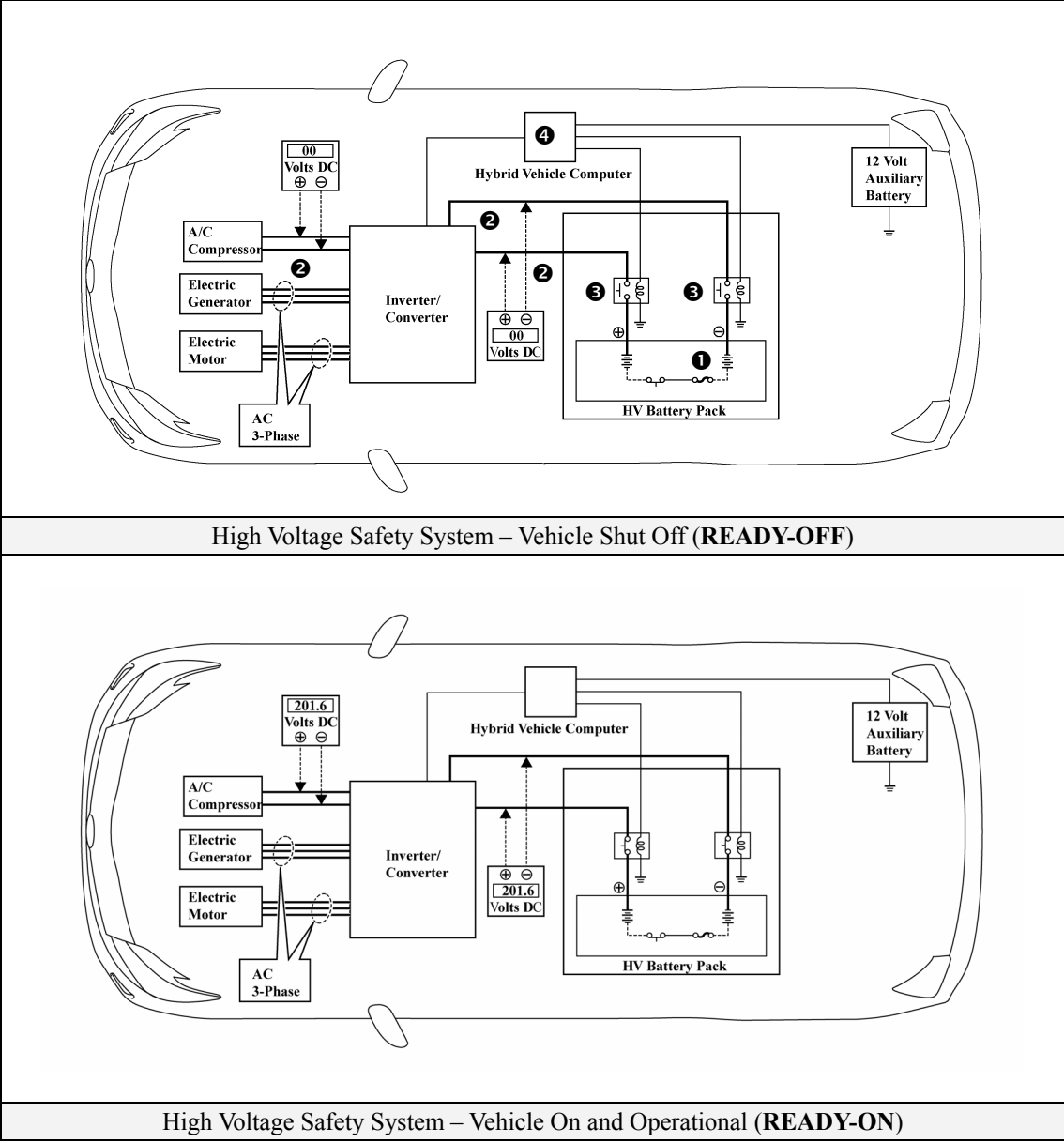

Precaution to be observed when dismantling the vehicle



WARNING:

- *The high voltage system may remain powered for up to 10 minutes after the vehicle is shut off or disabled. To prevent serious injury or death from severe burns or electric shock, avoid touching, cutting, or opening any orange high voltage power cable or high voltage component.*

Necessary Items

- Protective clothing such as insulated gloves (electrically insulated), rubber gloves, safety goggles, and safety shoes.
- Insulating tape such as electrical tape that has a suitable electrical insulation rating.
- Before wearing insulated gloves, make sure that they are not cracked, ruptured, torn, or damaged in any way. Do not wear wet insulated gloves.
- An electrical tester that is capable of measuring DC 750 Volts or more.

Spills

The Prius contains the same common automotive fluids used in other non-hybrid Toyota vehicles, with the exception of the NiMH electrolyte used in the HV battery pack. The NiMH battery electrolyte is a caustic alkaline (pH 13.5) that is damaging to human tissues. The electrolyte, however, is absorbed in the cell plates and will not normally spill or leak out even if a battery module is cracked. A catastrophic crash that would breach both the metal battery pack case and a metal battery module would be a rare occurrence.

A caustic alkaline is at the opposite end of the pH scale from a strong acid. A safe (neutral) substance is approximately in the middle of this scale. Adding a weak acidic mixture, such as a dilute boric acid solution or vinegar, to the caustic alkaline electrolyte will cause the electrolyte to be neutralized. This is similar but opposite to the use of baking soda to neutralize a lead-acid battery electrolyte spill.

A Toyota Material Safety Data Sheets (MSDS) is attached to this document.

- Handle NiMH electrolyte spills using the following Personal Protective Equipment (PPE):
 - Splash shield or safety goggles. A fold down face shield is not acceptable for acid or electrolyte spills.
 - Rubber, latex or nitrile gloves.
 - Apron suitable for alkaline.
 - Rubber boots.

- Neutralize NiMH electrolyte.
 - Use a boric acid solution or vinegar.
 - Boric acid solution - 800 grams boric acid to 20 liters water or 5.5 ounces boric acid to 1 gallon of water.

Dismantling the vehicle

The following 2 pages contain general instructions for use when working on a Prius. Read these instructions before proceeding to the HV battery removal instructions on page 18.



WARNING:

- **The high voltage system may remain powered for up to 10 minutes after the vehicle is shut off or disabled. To prevent serious injury or death from severe burns or electric shock, avoid touching, cutting, or opening any orange high voltage power cable or any high voltage component.**

1. Shut off the ignition (**READY** indicator is off). Then disconnect the cable from the auxiliary battery negative (-) terminal.

- (1) Remove the center deck board.
- (2) Remove the center auxiliary box and battery cover.
- (3) Disconnect the battery negative terminal.

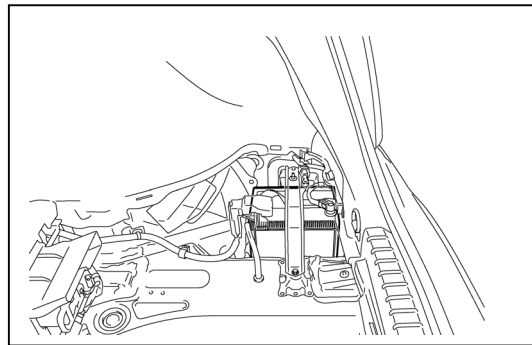

2. Remove the service plug grip.

Caution:

Wear insulated gloves for the following 3 steps.

- (1) Slide the handle of the service plug grip to the right.
- (2) Raise the release handle of the service plug grip
- (3) Remove the service plug grip.
- (4) Apply insulating tape to the socket of the service plug grip to insulate it.

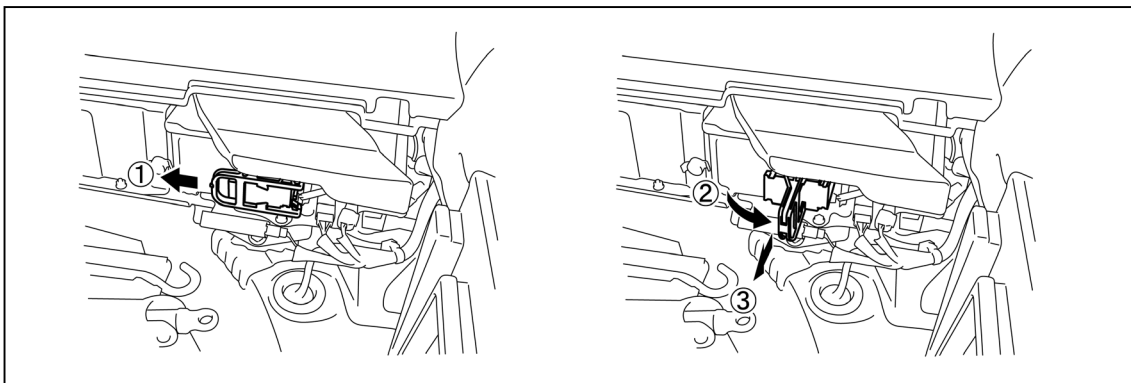

3. Carry the removed service plug grip in your pocket to prevent other staff from accidentally reinstalling it while you are dismantling the vehicle.
4. Make other staff aware that a high-voltage system is being dismantled by using the following sign: CAUTION: HIGH-VOLTAGE. DO NOT TOUCH (see page 17).
5. If the service plug grip cannot be removed due to damage to the vehicle, remove the **IGCT fuse (30A)** and **AM2 fuse (7.5A)**.

Caution:

This operation shuts off the HV system. Be sure to wear insulated gloves because high voltage is not shut off inside the HV battery. When it is possible to remove the service plug grip, remove it and continue the procedure.

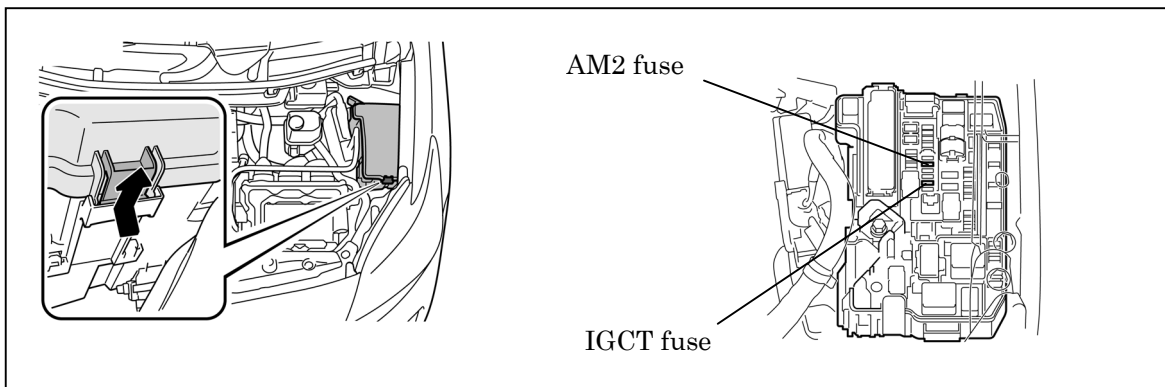

6. After disconnecting or exposing a high-voltage connector or terminal, insulate it immediately using insulating tape. Before disconnecting or touching a bare high-voltage terminal, wear insulated gloves.
7. Check the HV battery and nearby area for leakage. If you find any liquid, it may be strong alkaline electrolyte. Wear rubber gloves and goggles and neutralize the liquid using a saturated boric acid solution or vinegar. Then wipe up the liquid using waste rags etc.

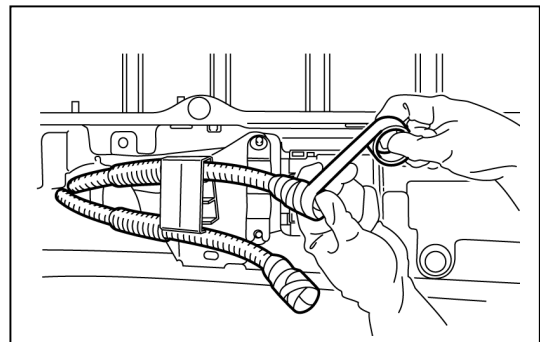

8. If the electrolyte comes into contact with your skin, wash the skin immediately using a saturated boric acid solution or a large amount of water. If the electrolyte adheres to any article of clothing, take the clothing off immediately.
9. If the electrolyte comes into contact with your eye(s), call out loudly for help. Do not rub your eye(s). Instead, wash the eye(s) with a dilute boric acid solution or a large amount of water and seek medical care.
10. With the exception of the HV battery, remove parts by following procedures which are similar to conventional Toyota vehicles. For the removal of the HV battery, refer to the following pages.

Person in charge: _____

CAUTION:
HIGH-VOLTAGE.
DO NOT TOUCH.

CAUTION:
HIGH-VOLTAGE.
DO NOT TOUCH.

Person in charge: _____

When performing work on the HV system, fold this sign and
put it on the roof of the vehicle.

Removal of HV battery



WARNING:

- **Be sure to wear insulated gloves when handling high-voltage parts.**
- **Even if the vehicle is shut off and the relays are off, be sure to remove the service plug grip before performing any further work.**
- **Power remains in the high voltage electrical system for 10 minutes even after the HV battery pack is shut off because the circuit has a condenser that stores power.**
- **Make sure that the tester reading is 0 V before touching any high-voltage terminals which are not insulated.**
- **The SRS may remain powered for up to 90 seconds after the vehicle is shut off or disabled. To prevent serious injury or death from unintentional SRS deployment, avoid cutting the SRS components.**

1. Shut off the ignition (**READY** indicator is off).
2. Remove the tonneau cover (with tonneau cover).
3. Remove the 12volt auxiliary battery.
 - (1) Remove the center deck board.

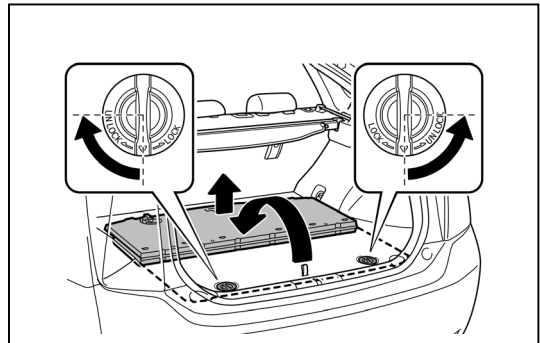

- (2) Remove the center auxiliary box.
- (3) Remove the battery cover and battery service hole cover.

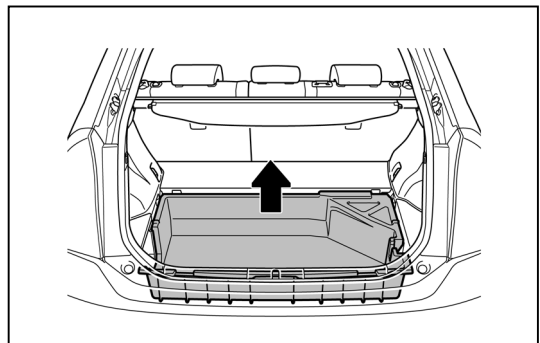

- (4) Disconnect the cable from the auxiliary battery negative (-) terminal.
- (5) Disconnect the cable from the auxiliary battery positive (+) terminal.
- (6) Remove the 12volt auxiliary battery.

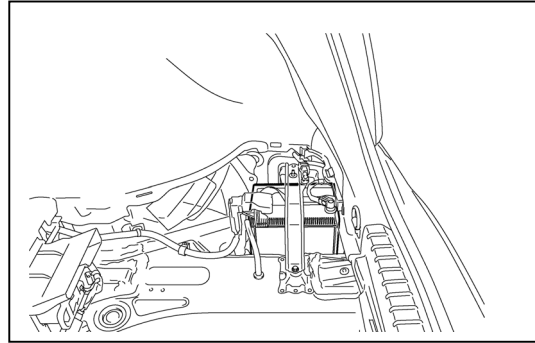

4. Remove the service plug grip.

Caution:

Wear insulated gloves for the following 3 steps.

- (1) Raise the release handle of the service plug grip as shown in the illustration below.
- (2) Remove the service plug grip.
- (3) Apply insulating tape to the socket of the service plug grip to insulate it.

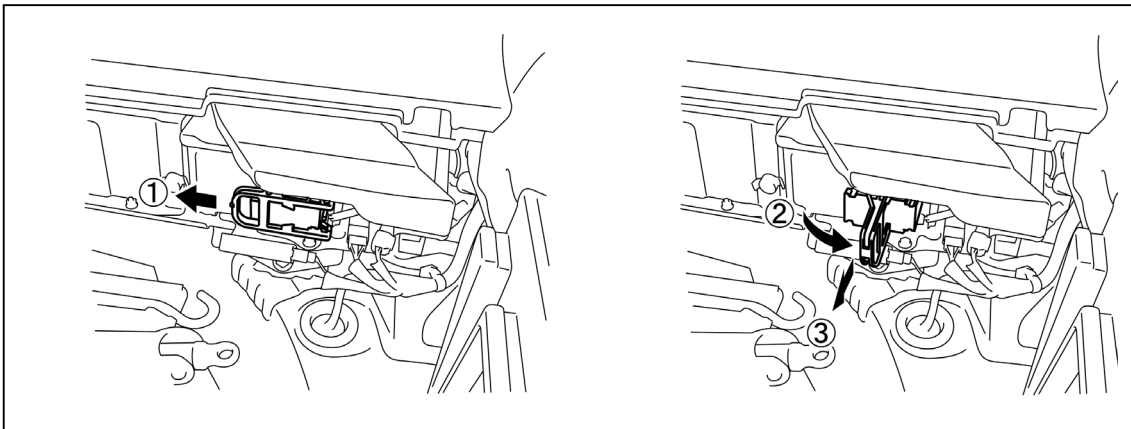
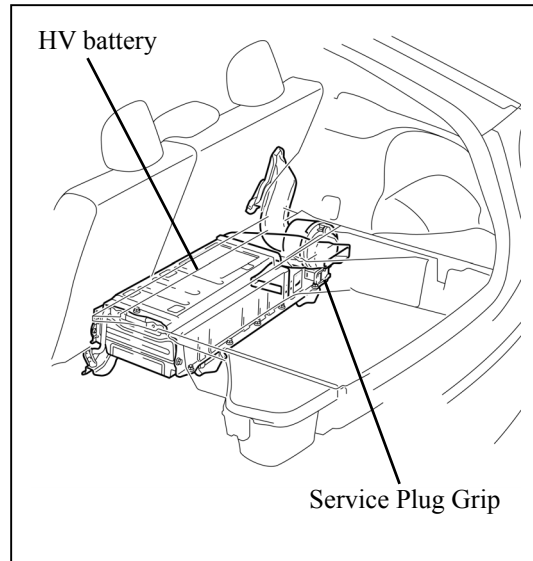

5. Remove the 9 bolts and inverter terminal cover.

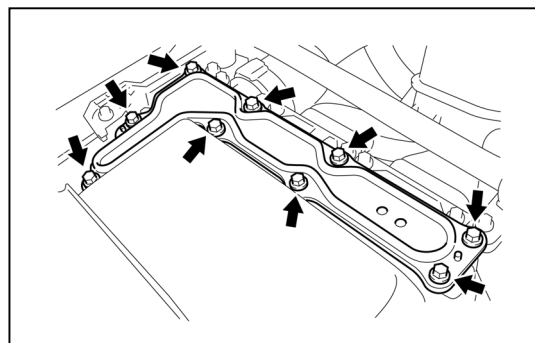

6. Check the voltage at the terminals in the inspection point in the power control unit.

Caution:

Wear insulated gloves.

To prevent serious injury or death, do not proceed with dismantling of the HV system until the voltage at the terminals in the inspection point is 0 V.

Standard voltage: 0 V

Hint:

Set the tester to DC 750 Volts measure the voltage.

This inspection is performed to verify that it is safe to remove the HV battery.

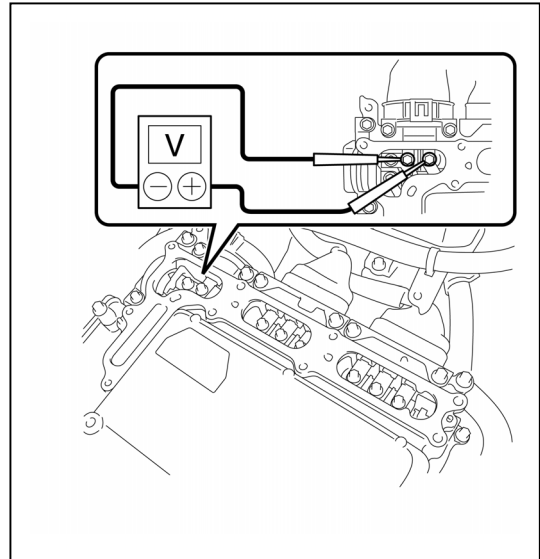

7. Cut the rear center seatbelt.
8. Remove the rear seat cushion assembly.

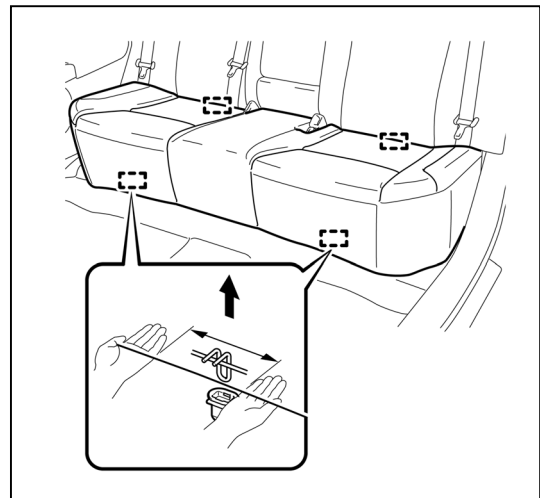

9. Remove the rear side seatback assembly
RH

(1) Remove the bolt.

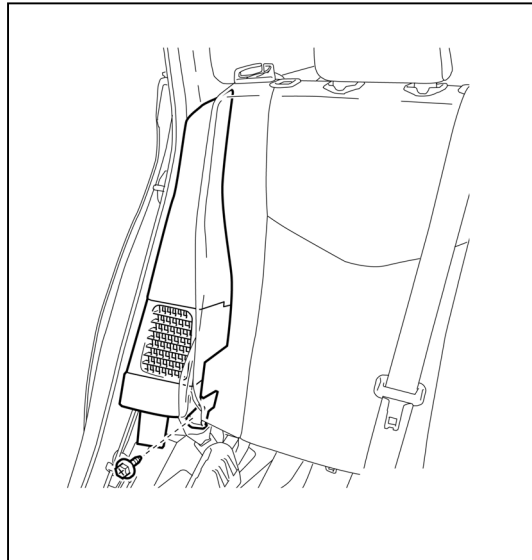

(2) Disengage the guides and remove the rear
side seatback assembly RH.

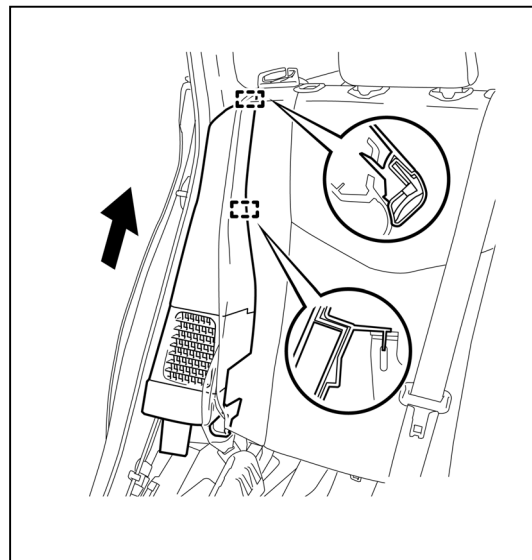

10. Remove the rear seatback assembly LH.

(1) Fold the rear seatback assembly LH
forward.

(2) Disengage the fastener.

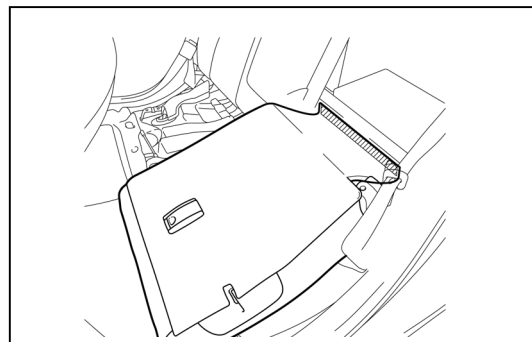

- (3) Remove the 2 bolts and rear seatback assembly LH.

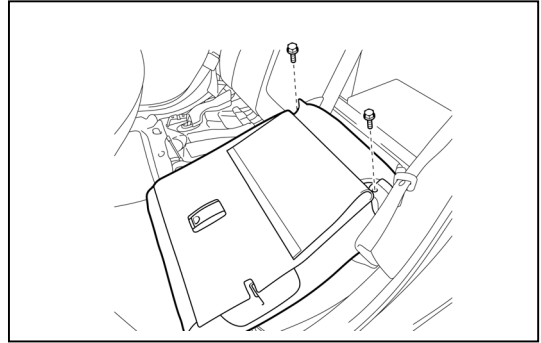

13. Remove the rear seatback assembly RH.

- (1) Fold the rear seatback assembly LH forward.
(2) Disengage the fastener.

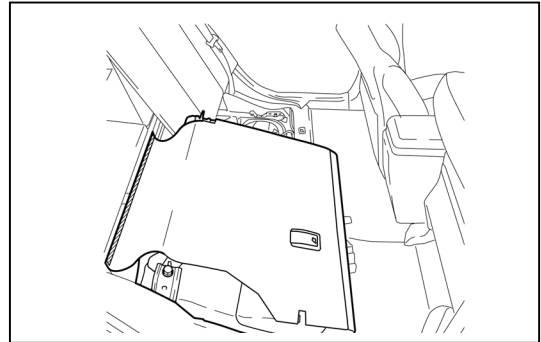

- (3) Remove the 2 bolts and rear seatback assembly LH.

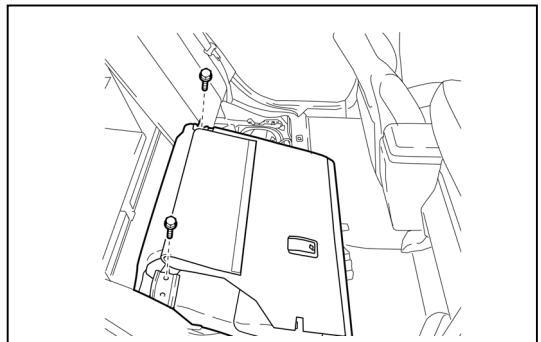

14. Remove the rear No. 1 floor board sub-assembly.

- (1) Disengage the 2 claws and 2 clips, and remove the rear No. 1 floor board sub-assembly.

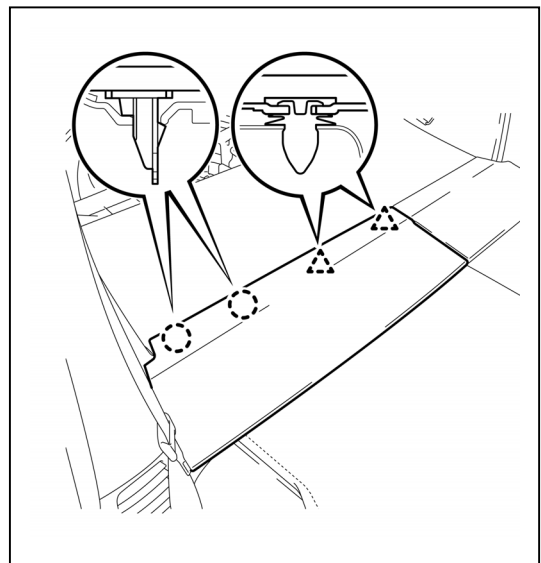

15. Remove the rear No. 2 floor board sub-assembly.

- (1) Disengage the 2 claws and 2 clips, and remove the rear No. 1 floor board sub-assembly.

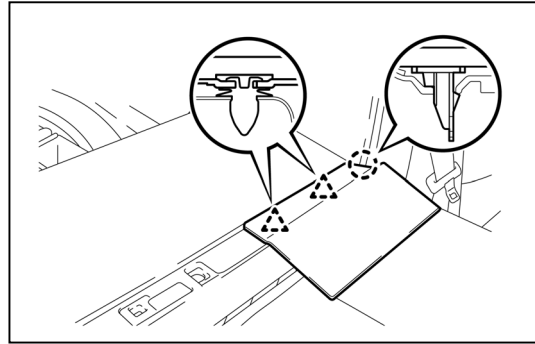

16. Remove the rear No. 1 floor board.

- (1) Remove the bolt.
- (2) Disengage the 2 claws and 2 clips, and remove the rear No. 1 floor board.

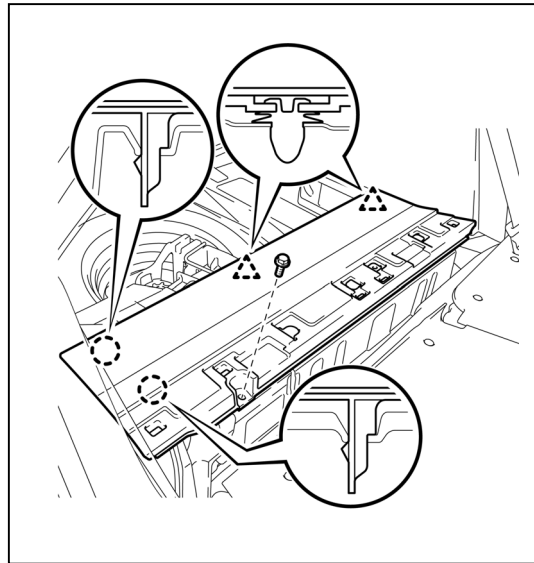

17. Remove the deck trim side panel assembly RH.

- (1) Using a screwdriver, disengage the claw and remove the tonneau cover holder cap.

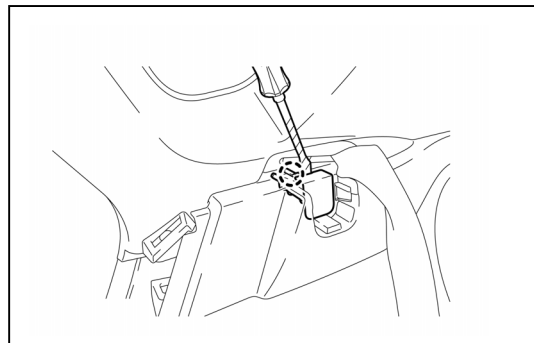

- (2) Remove the 2 bolts.
- (3) Disengage each guide and remove the 2 luggage hold belt striker assemblies.
- (4) Remove the screw.
- (5) Disengage the 7 claws and 2 clips, and remove the deck trim side panel assembly RH.

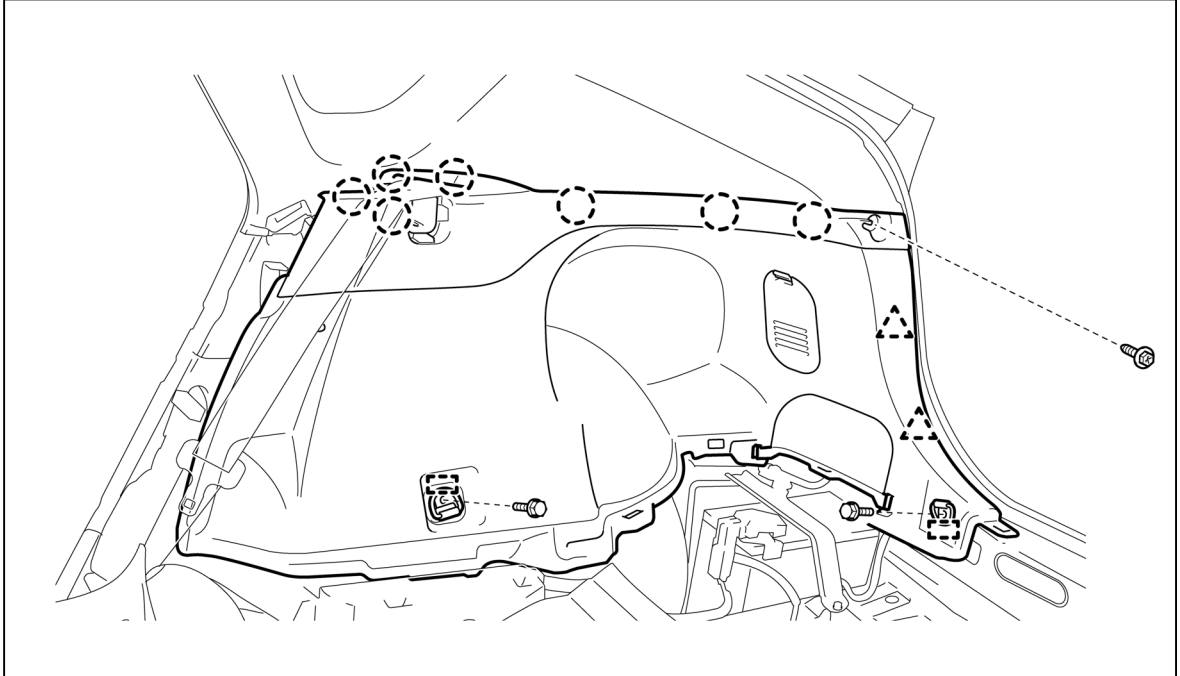

18. Remove the rear floor board spacer.

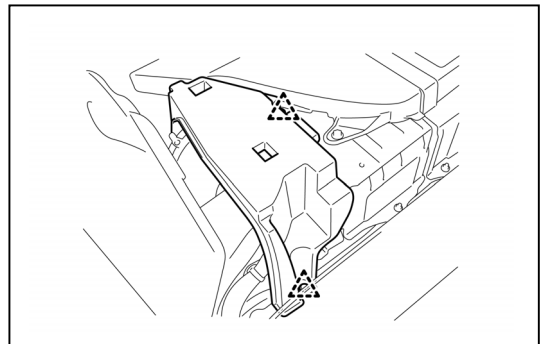

19. Remove the No. 1 hybrid battery exhaust duct.

Caution:

Wear insulated gloves for the following 2 steps.

(1) Using the service plug grip, remove the battery cover lock striker.

Hint:

Insert the projecting part of the service plug grip and turn the button of the battery cover lock striker counterclockwise to release the lock.

(2) Remove the 4 nuts and upper hybrid battery cover sub-assembly.

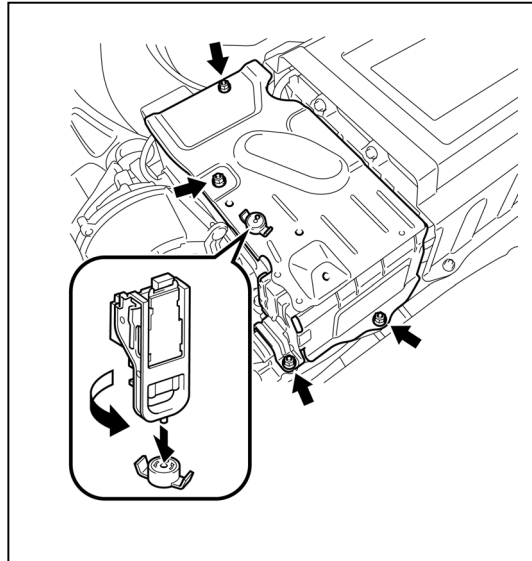

20. Remove the No. 1 hybrid battery intake duct.

(1) Remove the 2 clips and No. 1 hybrid battery intake duct.

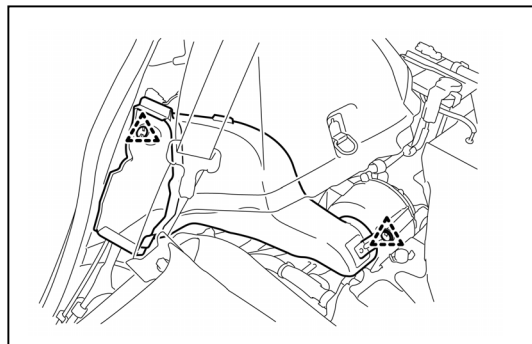

21. Remove the battery cooling blower assembly.

(1) Disconnect the 3 wire harness clamps.

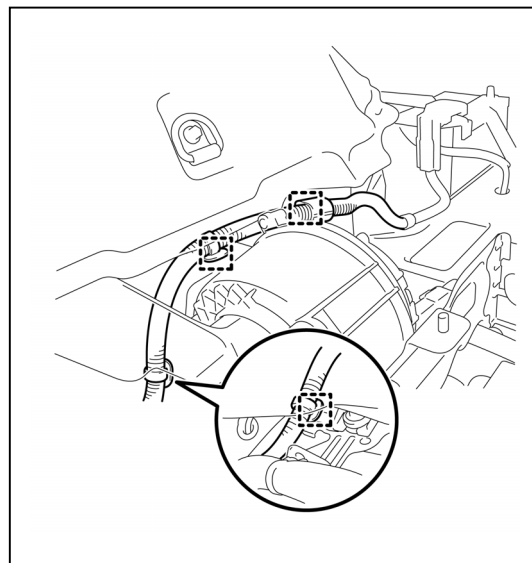

- (2) Disconnect the battery cooling blower assembly connector and clamp.
- (3) Remove the 2 bolts, nut and battery cooling blower assembly.

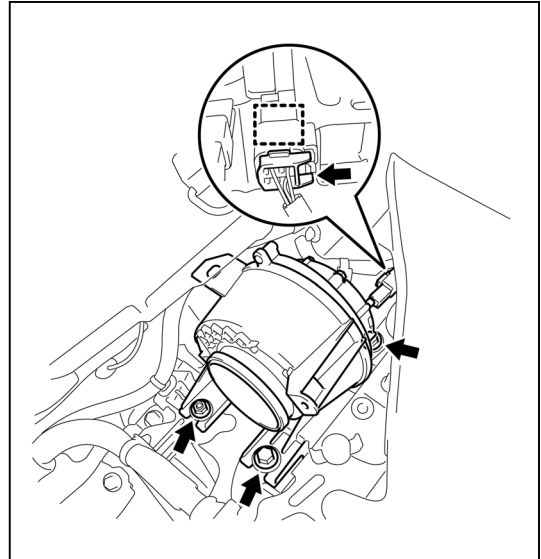

- 22. Remove the 2 bolts and child restraint seat anchor bracket sub-assembly LH.

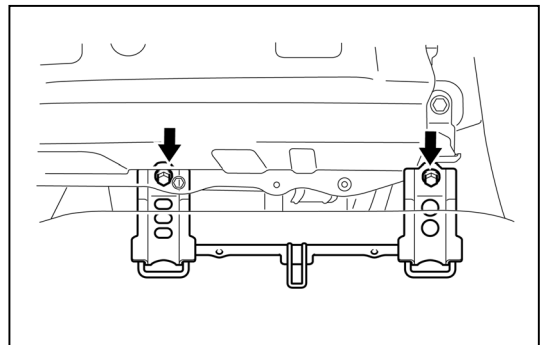

- 23. Remove the 2 bolts and child restraint seat anchor bracket sub-assembly RH.

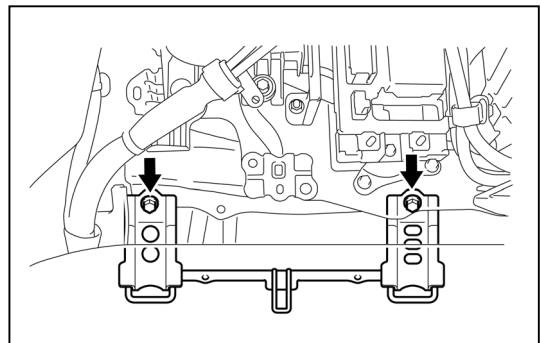

- 24. Disconnect the 2 frame wires.

Caution:

Wear insulated gloves.

Notice:

Insulate the terminals of the removed frame wire with insulating tape.

- (1) Remove the 2 nuts, then disconnect the frame wire from the hybrid battery junction block assembly.
- (2) Disconnect the clamp and frame wire.

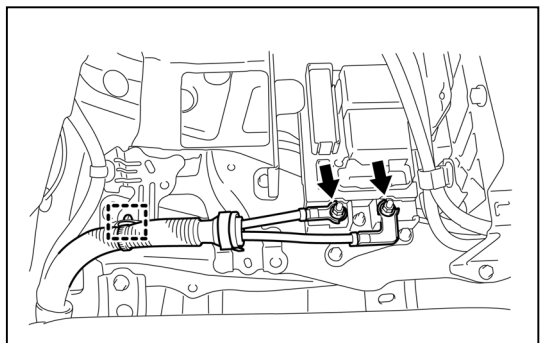

25. Remove the HV battery assembly.

Caution:

Wear insulated gloves.

- (1) Disconnect the connector and electrical key oscillator clamp.

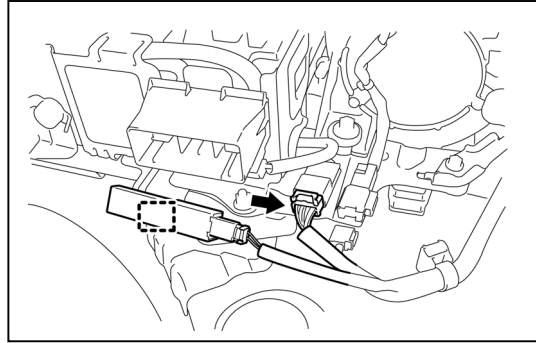

- (2) Disconnect the battery room ventilation hose from the floor panel.

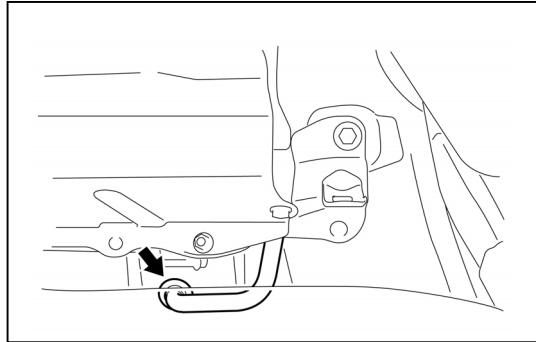

- (3) Remove the 4 bolts and HV battery assembly.

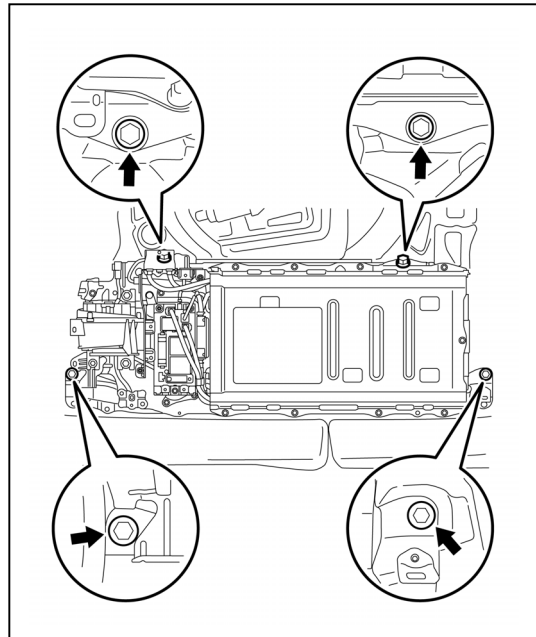







26. The HV battery pack is recyclable. Contact your Toyota distributor (if included on the HV battery caution label) or contact the nearest Toyota dealer (see the next 2 pages for samples of the HV battery caution label).

Caution:







After removing the HV battery, do not reinstall the service plug grip to the HV battery.

HV Battery Caution Label







1. For U.S.A.

⚠ DANGER									
High Voltage Inside/Alkaline Electrolyte		Ni-MH							
<p>To avoid injuries, burns or electric shocks:</p> <ul style="list-style-type: none"> •Never disassemble this battery unit or remove its covers. -Service by Qualified Technician.- •Avoid contact alkaline electrolyte with eyes, skin or clothes. In event of accident, flush with water and get medical help immediately. •Keep children away from this unit. •Do not puncture or impact on this unit when operating forklift, or expose to open flame or incinerate, or expose to liquids when storing this unit, as excessive heat may generate fire and electrolyte may leak out. 									
<p>To the Qualified EV Technicians:</p> <p>Be sure to read the Repair Manual when servicing or replacing the battery.</p>									
<p>HV Battery Recycling Information</p> <ul style="list-style-type: none"> •Please transport this battery in accordance with all applicable laws. •Be sure to consult your dealer or the following address for replacing and disposing of this battery. 									
Residents In U.S.A.			Residents In PUERTO RICO						
♦TOYOTA MOTOR SALES U.S.A., INC. TORRANCE, CAL. 90501 Phone: 1-800-331-4331		♦SERVCO PACIFIC INC. HONOLULU, HAWAII 96813 Phone: 808-839-2273		♦TOYOTA DE PUERTO RICO HATO REY, PUERTO RICO Phone: 787-751-1000		B			

2. For CANADA

⚠ DANGER									
High Voltage Inside / Alkaline Electrolyte		Ni-MH							
Haute tension à l'intérieur / Electrolyte alcalin									
<p>To avoid injuries, burns or electric shocks:</p> <ul style="list-style-type: none"> •Never disassemble this battery unit or remove its covers. -Service by Qualified Technician.- •Avoid contact alkaline electrolyte with eyes, skin or clothes. In event of accident, flush with water and get medical help immediately. •Keep children away from this unit. •Do not puncture or impact on this unit when operating forklift, or expose to open flame or incinerate, or expose to liquids when storing this unit, as excessive heat may generate fire and electrolyte may leak out. 									
<p>Afin d'éviter des blessures et brûlures et tout chocs électriques:</p> <ul style="list-style-type: none"> •Ne jamais démonter cet ensemble batterie ni enlever ses couvercles. -Confier l'entretien à un technicien qualifié.- •Eviter tout contact de l'électrolyte alcalin avec les yeux, la peau ou les vêtements. En cas d'accident, rincer à l'eau et contacter un médecin immédiatement. •Garder cet ensemble hors de portée des enfants. •Ne pas percer cet ensemble et ne pas lui faire subir d'impact lors de l'utilisation du chariot élévateur. Ne pas l'exposer à une flamme vive ni l'incinérer. Ne pas l'exposer à un liquide lors du stockage. Une chaleur excessive pourrait provoquer un incendie et l'électrolyte pourrait fuir. 									
<p>To the Qualified EV Technicians:</p> <p>A l'attention des techniciens spécialistes en véhicules électriques:</p> <p>Be sure to read the Repair Manual when servicing or replacing the battery. Veiller à lire le manuel de réparation lors de l'entretien ou du remplacement de la batterie.</p>									
<p>HV Battery Recycling Information</p> <p>Information sur le recyclage de batterie de véhicule hybride</p> <ul style="list-style-type: none"> •Please transport this battery in accordance with all applicable laws. •Be sure to consult your dealer or the following address for replacing and disposing of this battery. •Prière de transporter cette batterie conformément à toutes les lois applicables. •Pour le remplacement et la mise au rebut de cette batterie, veiller à consulter un votre concessionnaire ou se renseigner à l'adresse suivante. 									
TOYOTA CANADA INC. ONE TOYOTA PLACE SCARBOROUGH, ONTARIO M1H 1H9 Phone: 1-888-TOYOTA-8 (1-888-869-6828)			URL: www.toyota.ca						C

3. For Europe

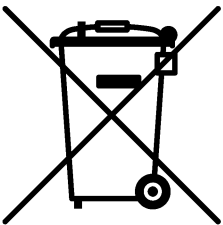
⚠ DANGER		      
High Voltage Inside / Alkaline Electrolyte Haute tension à l'intérieur / Electrolyte alcalin		Ni-MH
<p>To avoid injuries, burns or electric shocks:</p> <ul style="list-style-type: none"> ● Never disassemble this battery unit or remove its covers. -Service by Qualified Technician.- ● Avoid contact alkaline electrolyte with eyes, skin or clothes. In event of accident, flush with water and get medical help immediately. ● Keep children away from this unit. ● Do not puncture or impact on this unit when operating forklift, or expose to open flame or incinerate, or expose to liquids when storing this unit, as excessive heat may generate fire and electrolyte may leak out. <p>Afin d'éviter des blessures et brûlures et tout chocs électriques:</p> <ul style="list-style-type: none"> ● Ne jamais démonter cet ensemble batterie ni enlever ses couvercles. -Confier l'entretien à un technicien qualifié.- ● Eviter tout contact de l'électrolyte alcalin avec les yeux, la peau ou les vêtements. En cas d'accident, rincer à l'eau et contacter un médecin immédiatement. ● Garder cet ensemble hors de portée des enfants. ● Ne pas percer cet ensemble et ne pas lui faire subir d'impact lors de l'utilisation du chariot élévateur. Ne pas l'exposer à une flamme vive ni l'incinérer. Ne pas l'exposer à un liquide lors du stockage. Une chaleur excessive pourrait provoquer un incendie et l'électrolyte pourrait fuir. 		
	<p>To the Qualified EV Technicians: A l'attention des techniciens spécialistes en véhicules électriques:</p> <p>Be sure to read the Repair Manual when servicing or replacing the battery. Veiller à lire le manuel de réparation lors de l'entretien ou du remplacement de la batterie.</p>	
	<p>HV Battery Recycling Information Information sur le recyclage de batterie de véhicule hybride</p> <ul style="list-style-type: none"> ● Please transport this battery in accordance with all applicable laws. ● Be sure to consult your dealer or your national distributor as mentioned in your Dealer Guide-Book for replacing and disposing of this battery. ● Prière de transporter cette batterie conformément à toutes les lois applicables. ● Pour le remplacement et la disposition de cette batterie, se rassurer de consulter un votre concessionnaire ou distributeur national comme mentionnées dans le guide des concessionnaires. 	
	D	